

ARTICLE III – ATHLETICS

As an international sports program, Special Olympics has created these rules based upon those of the International Association of Athletics Federations (IAAF). In international competitions, IAAF rules shall be employed, at Program and local level competitions, National Governing Body (NGB) rules may be employed, except when they are in conflict with the Official Special Olympics Sports Rules.

An athlete with Down syndrome who has been diagnosed with Atlanto-axial instability may not participate in the pentathlon and high jump events.

1. 100 Meter Run
2. 200 Meter Run
3. 400 Meter Run
4. 800 Meter Run
5. 1500 Meter Run
6. 3000 Meter Run
7. 5000 Meter Run
8. 10000 Meter Run
9. Half Marathon (Running)
10. Marathon (Running)
11. Hurdle events
 - a. Men 110 Meters
 - b. Women 100 Meters
12. 4 x 100 Meter Relay
13. 4 x 400 Meter Relay
14. High Jump
15. Long Jump
16. Shot Put
 - a. Men 4 kg/ 8.13 lbs
 - b. Women 2.72 kg/ 6 lbs
 - c. Men (8-11 yrs - 2.72 kg/ 6 lbs)
 - d. Women (8-11 yrs - 1.81 kg/ 4 lbs)
17. Pentathlon (100 Meters, Long Jump, Shot Put, High Jump, 400 Meters)
18. 100 Meter Unified Sports Run
19. 200 Meter Unified Sports Run
20. 400 Meter Unified Sports Run
21. 800 Meter Unified Sports Run
22. 1500 Meter Unified Sports Run
23. 3000 Meter Unified Sports Run
24. 5000 Meter Unified Sports Run
25. 10000 Meter Unified Sports Run
26. 4 x 100 Meter Unified Sports Run
27. 4 x 400 Meter Unified Sports Run





28. Unified Sports High Jump
29. Unified Sports Long Jump
30. Unified Sports Shot Put
31. Unified Sports Pentathlon

Race Walking

32. 400 Meter Walk
33. 800 Meter Walk

Wheelchair Events

34. 100 Meter Wheelchair Race
35. 200 Meter Wheelchair Race
36. 400 Meter Wheelchair Race
37. Wheelchair Shot Put
 - a. Men 1.81 kg/ 4 lbs
 - b. Women 1.81 kg / 4lbs.

Long Distance Racing and Walking

38. 1500 Meter (Walking and Running)
39. 3000 Meter (Walking and Running)
40. 5000 Meter (Walking and Running)
41. 10,000 Meter (Walking and Running)
42. 1500 Meter Unified Sports Race (Walking and Running)
43. 3000 Meter Unified Sports Race (Walking and Running)
44. 5000 Meter Unified Sports Race (Walking and Running)
45. 10000 Meter Unified Sports Race (Walking and Running)
46. 15000 Meter Unified Sports Race (Walking and Running)
47. 1500 Meter Unified Sports Race (Walking)
48. Half Marathon Unified Sports Race (Running)
49. Marathon Unified Sports Race (Running)

The following events provide meaningful competition for athletes with lower ability levels:

50. 25 Meters dash
51. 50 Meters dash
52. 25 Meter Walk
53. 50 Meter Walk
54. 100 meter Walk
55. Softball Throw
56. Standing Long Jump
57. 10 Meter Assisted Walk
58. 25 Meter Assisted Walk
59. 50 Meter Assisted Walk
60. 10 Meter Wheelchair race
61. 25 Meter Wheelchair Race

- 62. 30 Meter Wheelchair Slalom
- 63. 4 x 25 Meter Wheelchair Shuttle Relay
- 64. 30 Meter Motorized Wheelchair Slalom
- 65. 50 Meter Motorized Wheelchair Slalom
- 66. 25 Meter Motorized Wheelchair Obstacle Race
- 67. Ball Throw for Distance (tennis ball)

SECTION B – RULES OF COMPETITION

1. General Rules and Modifications

a. Use of blocks and starting race

- 1) In races up to and including the 400 meters, the athletes have the option of using or not using blocks.
- 2) In competition, regardless of whether the athletes are using blocks in races 400 meters or below, the commands of the Starter in English, French or in his own language shall be “on your marks,” “set,” and when all competitors are set, the gun shall be fired.
- 3) In races (800m or longer), the command shall be “on your marks” and when all competitors are steady, the gun shall be fired. A competitor shall not touch the ground with his/her hand(s).
- 4) Starting races longer than 400m:
 - a) 800m distance: Runner will run in the lanes through the first turn and break toward lane one at the breakline marked after the first turn.
 - b) 1500m and greater distances: A waterfall start shall be used.
 - c) 1600m Relay: A three-turn stagger shall be used to start. The first leg shall be run entirely in lanes. The second leg shall start in his/her lane and break toward lane one at a breakline marked after the first turn.
- 5) All races up to and including 100m shall be run on a "straight-away" on a regular 400m track.
- 6) All runners shall start from behind the start line. A runner completes the race when his/her torso reaches the perpendicular plane of the nearer edge of the finish line.
- 7) All races up to the 100m shall be measured from the finish line. The start line will be adjusted for the various distances.
- 8) The starter shall give each competitor a chance to do his/her best by:
 - a) Giving the competitors ample time to settle down after taking their marks.
 - b) Starting the sequence over if any runner is off-balance.
 - c) Not holding the runners too long after the set command.

b. Lane Violations

- 1) In all races run in lanes, each competitor shall keep within his allocated lane from start to finish.
- 2) If a competitor is pushed or forced by another person to run outside his lane, and if no material advantage is gained, the competitor should not be disqualified.
- 3) If an athlete either:
 - a) runs outside his/her lane in the straight, or





- b) runs outside the outer line of his lane on the bend, with no material advantage thereby being gained, and no other runner is obstructed, then the competitor should not be disqualified.
- c. Race Walking
- 1) Athlete must have one foot in touch with the ground at all times.
 - 2) In all race walking events, an athlete does not have to have a straight advancing leg while competing.
 - 3) In race walking events, up to and including the 400 meters, the competitor shall be disqualified with no prior warning when, in the opinion of two or more officials, an advantage has been gained.
- d. Long Jump
- 1) In the long jump, an athlete must be able to jump at least one meter which is the minimum distance between the take-off board to the sand pit.
 - 2) Each competitor shall be allowed three non-consecutive jumps. The athlete's best jump will be used for scoring.
 - 3) All three jumps shall be measured and recorded for breaking ties. The best jump shall be used for scoring.
 - 4) Distance will be measured from the closest impression on the landing area made by any part of the body or limbs to the take-off line for all jumps.
 - 5) In jumping events, prior to competition, athletes may have assistance from an official to mark their take-off mark.
- f. Standing Long Jump
- 1) Competitors shall start with both feet behind a designated take-off line and on the ground.
 - 2) When starting, competitor's toes shall be behind the take-off line.
 - 3) A competitor shall use both feet on the take-off. He/she may rock backward and forward lifting his/her heels and toes alternately, but he/she may not lift either foot clear off the ground.
 - 4) Each competitor shall be allowed three non-consecutive jumps. The athlete's best jump will be used for scoring.
 - 5) Distance will be measured from the closest impression on the landing area made by any part of the body or limbs to the take-off line for all jumps.
 - 6) When possible, it is strongly suggested that the standing long jump event be conducted in sand filled jumping pits. The take-off line shall be placed at the end of the running long jump runway. If a mat is used it should be long enough to include both take-off and landing areas, and the mat must be secured safely to the surface to prevent slipping.
 - 7) In jumping events, prior to competition, athletes may have assistance from an official to mark their take-off mark.
- g. High Jump
- 1) The competitor shall take off from one foot.
 - 2) The minimum opening height for all high jump competitions shall be 1m.
 - 3) Competitors shall not dive forward over the bar or take off from a two-footed take off.
 - 4) In jumping events, prior to competition, athletes may have assistance from an official to mark their take-off marks.

- 5) An athlete with Down Syndrome who has been diagnosed with Atlanto-axial instability may not participate in the pentathlon and the high jump. For additional information and the procedure for waiver of this restriction, please refer to Article I, Section L, 7, f.
- h. Shot Put
- 1) The shot may be either steel, brass, or a synthetic-covered implement.
 - 2) A legal put shall be made from within the circle and the athlete, or his/her wheelchair, in the course of an attempt may not touch the top edge of the stop-board, the top of the iron ring, or any surface outside of the circle. It is legal to touch the inside of the stop-board or the iron band.
 - 3) The use of any mechanical aid shall not be allowed. For protective purposes only the wrist may be taped.
 - 4) The shot shall be put from the shoulder with one hand only. The competitor takes a stance in the circle to commence a put, the shot shall touch or be in close proximity to the neck or the chin and the hand shall not be dropped below this position during the action of putting. The shot shall not be taken behind the line of the shoulders.
 - 5) The put shall be declared foul and shall not be measured if, after entering the circle and starting the put, the competitor commits any of the following:
 - a) Uses any method contrary to the definition of legal put.
 - b) Causes the shot to fall on or outside the lines marking the landing sector.
 - c) Puts a shot which does not conform to the legal requirements.
 - 6) Each competitor shall be allowed three non-consecutive throws. All three throws shall be measured and recorded for breaking ties. The longest measurement of the three throws will be used for scoring.
- i. Softball Throw – This event provides meaningful competition for athletes with lower ability levels.
- 1) A 30 centimeter (11 3/4") in circumference softball shall be used.
 - 2) Competitors may use any type of throw.
 - 3) The throwing area should be set up as follows:
 - a) Mark off two parallel lines which are 2.85 meters in length, with each of the ends being 2 meters apart. At the back end of the throwing area, place a mark 0.10 in length directly in the middle of the two end lines. (This is your pull through point for measurement.) From this mark, extend an imaginary parallel line out 3 meters, mark this point, and draw an arc connecting both sidelines which intersect this point. The ball must land within a sector determined by a 40 degree angle emanating from the center of the back line. Extend two lines out which intersect both points where the arc meets the sidelines.





b) Softball Throwing Area Diagram

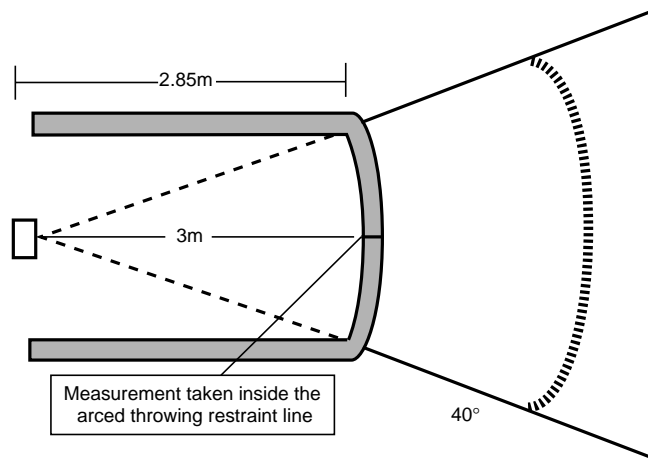

- 4) Each competitor shall be allowed three non-consecutive throws. The longest measurement of the three throws will be used for scoring. Throws will be measured from the inner edge of the arced throwing restraining line. All three throws should be measured and recorded for the purpose of breaking ties. The best score shall be used for scoring.
- j. 100/110 Meter Hurdles
 - 1) The height for the 100 meter hurdles shall be 0.762 meters, with the distance to the first hurdle from the starting line being 13 meters, the distance between hurdles being 8.5 meters and the distance from the last hurdle to the finish line being 10.5 meters.
 - 2) The height for the 110 meter hurdles shall be 0.840 meters, with the distance to the first hurdle from the starting line being 13.72 meters, the distance between hurdles being 9.14 meters, and the distance from the last hurdle to the finish line being 14.02 meters.

HURDLE SETTING CHART

Distance of race	Height of hurdles	Distance from start line to first hurdle	Distance between hurdles	Distance from last hurdle to finish line
110 meters	0.840 meters	13.72 meters	9.14 meters	14.02 meters
100 meters	0.762 meters	13 meters	8.5 meters	10.5 meters

- k. Pentathlon
 - 1) The five events comprising the pentathlon shall be conducted in the following order: 100 meter run, long jump, shot put, high jump, and 400 meter run.
 - 2) The Special Olympics Pentathlon scoring Tables may be found at the end of this section.
 - 3) The pentathlon shall be conducted on a one-day format. However, a two consecutive day format may be used with events one, two, and three on the first day and events four and five on the second day.
- i. Blind and Deaf Athletes
 - 1) A rope or sighted guide runner may be provided to assist athletes who are visually impaired.

- 2) A sighted guide runner may not be ahead of the athlete in any manner. At no time may the guide runner pull the athlete or propel the athlete forward by pushing.
 - 3) A tap start will be used for an athlete who is both deaf and blind.
 - 4) Guide runners must wear a bright orange running vest in order that they are clearly distinguished from competitors. These vests will be provided by the Games Organizing Committee.
2. **General Rules for Wheelchair Events**
- a. Athletes entering wheelchair events may also enter other events in athletics competition.
 - b. Athletes shall start with the first two wheels behind the start line.
 - 1) Athlete is timed from the smoke of the starter's pistol to when two wheels of the wheelchair reach the perpendicular plane of the nearer edge of the finish line.
 - c. Motorized wheelchairs shall not be allowed in regular wheelchair races.
 - d. Only athletes who ambulate by use of a wheelchair may participate in the events.
 - e. Athletes shall not be pushed, pulled or otherwise assisted during these events.
 - f. The lanes for the wheelchair events shall be made two track-lanes wide.
3. **25 Meter Wheelchair Race** – This event provides meaningful competition for athletes with lower ability levels.
- a. Competitors start with the first two wheels behind the start line.
 - b. A competitor completes the race when the first two wheels reach the perpendicular plane of the nearer edge of the finish line.
 - c. Each competitor must keep in his/her lane from start to finish and may not interfere, obstruct or impede the progress of another competitor. Infractions, at the discretion of the judges, may result in disqualification.
 - d. The starter shall give each athlete a chance to do his/her best.
4. **30 Meter Wheelchair Slalom** – This event provides meaningful competition for athletes with lower ability levels.
- a. Athlete maneuvers his/her chair through the course going to the right of the first obstacle and across the finish line without impeding another athlete on the course.
 - b. Knocking down a marker constitutes a violation, and a three-second penalty will be assessed.
5. **4 x 25 Meter Wheelchair Shuttle Relay** – This event provides meaningful competition for athletes with lower ability levels.
- a. Four persons shall make up a team. Each competitor will complete 25 meters of the relay.
 - b. The second, third and fourth competitors of a team may not leave the start line until the leading wheel(s) on the wheelchair of the teammate who precedes him/her crosses a takeoff line one meter in front and parallel to the starting line.
 - c. The fourth competitor completes the race when the first two wheels reach the perpendicular plane of the nearer edge of the finish line.
6. **General Rules for Motorized Wheelchair Events**
- a. These events are restricted to motorized wheelchairs only.
 - b. The first two wheels on each competitor's wheelchair will be regarded as the starting and finishing points of all races.
 - c. If a competitor varies from a sequence of obstacles, he/she must, without notice from any official, resume progress at the point prior to the incorrectly passed obsta-





cle before entering the next obstacle and complete the course in its entirety, or be disqualified. In essence, failure to complete the course as designed will result in disqualification.

- d. A competitor will be disqualified if that individual's coach (or assistants) enters the course boundaries during the running of the obstacle course. Coaches may instruct from outside the marked boundaries of the course. Judges and officials will not give directional cues.
 - e. When submitting entry times for Motorized Wheelchair Events, the entry form should state whether the time was achieved with a "high-speed" or a "low speed" setting.
7. **30 Meter Motorized Wheelchair Slalom** – This event provides meaningful competition for athletes with lower ability levels.

a. Equipment:

- 1) Chalk or tape
- 2) Traffic cones (i.e., Slalom flagpoles minimum of 1.22m or 4 ft. in height)
- 3) Stopwatches
- 4) Starter's gun

b. Set-Up:

- 1) Mark the start and finish lines 30 meters apart.
- 2) Place the cones on the start and finish lines 2 meters apart to create 4 start and finish gates and 4 lanes.
- 3) Beginning at the start line, place one cone in each lane at 5 meter intervals. Cones should be placed in the middle of the lanes.

c. Diagram – 30 and 50 Meter Motorized Wheelchair Slalom

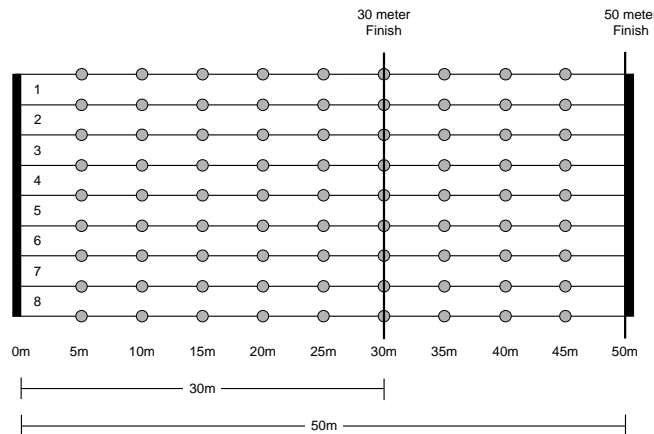

d. Rules:

- 1) The first two wheels on each competitor's wheelchair will be regarded as the starting and finishing points of all races.
- 2) Athlete starts slalom at the smoke of the starter's gun.
- 3) Athlete maneuvers his/her chair through the course going to the right of the first obstacle and across the finish line without impeding another athlete on the course. Knocking down a marker constitutes a violation, and a three-second penalty will be assessed.

- e. Score:
- 1) Athlete is timed from the smoke of the starter's gun to when the first two wheels on the motorized wheelchair reach the perpendicular plane of the nearer edge of the finish line.
 - 2) No penalty will be incurred as a result of touching a cone.
8. **50 Meter Motorized Wheelchair Slalom** – This event provides meaningful competition for athletes with lower ability levels.
- a. Equipment:
- 1) Cones
 - 2) Chalk
 - 3) Stopwatch
 - 4) Starter's Gun
- b. Set-Up:
- 1) Mark the start and finish lines 50 meters apart.
 - 2) Each athlete will use two lanes as his/her lane, sufficiently wide enough to allow for wheelchairs.
 - 3) Place cones on each line, two meters apart, to create start and finish gates for each line.
 - 4) Create lanes by placing cones or chalk lines down the track between the start and finish gates.
- c. Diagram:
- 1) Same as 30 Meter Motorized Wheelchair slalom.
- d. Rules:
- 1) Same as 30 Meter Motorized Wheelchair slalom.
- e. Score:
- 1) Same as 30 Meter Motorized Wheelchair slalom.
9. **25 Meter Motorized Wheelchair Obstacle Course** – This event provides meaningful competition for athletes with lower ability levels.
- a. Equipment:
- 1) Cones
 - 2) Chalk
 - 3) Stopwatch
 - 4) Starter's Gun
- b. Set-Up
- 1) Mark the start and finish lines 25 meters apart.
 - 2) Mark one box 2 meters from the start line and one box 2 meters from the finish line. Each box should be 3 meters in diameter.
 - 3) Place 4 cones between the boxes, each 3 meters apart.





d. Rules:

- 1) Athlete starts facing the course.
- 2) The athlete completes a 360 degree circle between the starting line and the starting line and the first cone. Upon completion, the athlete weaves in and out of four cones set three meters apart then completes a second 360 degree circle between the fourth cone and the finish line.
- 3) The box (3 m x 3 m) is used only as an indicator for the athlete to complete the 360-degree circle. No points and/or time shall be deducted for touching or going over the lines. The box can be outlined with tape or chalk.
- 4) Knocking down a marker constitutes a violation, and a three-second penalty will be assessed. Competitors who do not make an obvious attempt to go between each pair of markers are subject to disqualification at the discretion of the referee.
- 5) No more than three athletes per race.

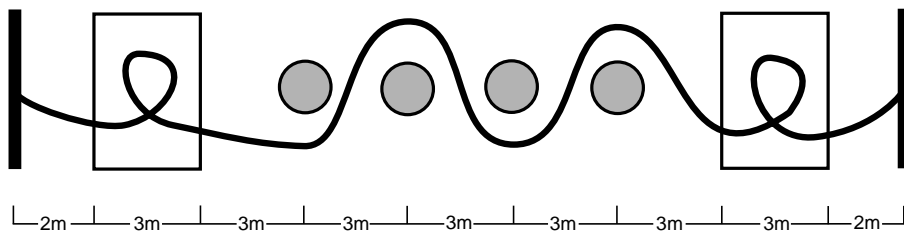

e. Score:

- 1) Athlete is timed from the smoke/fire of the starter's gun to when the leading wheels of the wheelchair reach the perpendicular plane of the nearer edge of the finish line.

10. Wheelchair Shot Put

- a. Refer to Section B 1.h.

11. 10 Meter Assisted Walk – This event provides meaningful competition for athletes with lower ability levels.

a. Equipment:

- 1) Athletes must provide their own assisted devices. Assisted devices may consist of canes, crutches or walker.
- 2) Cones
- 3) Chalk
- 4) Stopwatch
- 5) Starter's Gun

b. Set-Up:

- 1) Mark the start and finish lines 10 meters apart.
- 2) Each athlete will use two lanes as his/her lane, sufficiently wide enough to allow for assistive devices.
- 3) Place cones on each line, two meters apart, to create start and finish gates for each line.

- 4) Create lanes by placing cones or chalk lines down the track between the start and finish gates.
 - c. Rules:
 - 1) Athlete starts behind the start line with a walking aid.
 - 2) Athlete begins race at the smoke of the starter's gun.
 - 3) Athlete walks the ten meters using a walking aid.
 - 4) Athletes stays in his/her designated lane.
 - 5) Athlete may not receive assistance from coaches, officials, etc.
 - d. Score:
 - 1) Athlete is timed from the smoke of the starter's gun to when his/her torso crosses the finish line.
12. **25 Meter Assisted Walk** – This event provides meaningful competition to athletes with lower ability levels.
- a. Equipment: Same as the 10 Meter Assisted Walk.
 - b. Set-Up: Mark the start and finish lines 25 meters apart.
 - c. Rules: Same as the 10 Meter Assisted Walk. However, athlete walks the 25 meters using a walking aid.
 - d. Score: Same as the 10 Meter Assisted Walk.
13. **50 Meter Assisted Walk** – This event provides meaningful competition to athletes with lower ability levels.
- a. Equipment: Same as the 10 Meter Assisted Walk.
 - b. Set-Up: Mark the start and finish lines 50 meters apart.
 - c. Rules: Same as the 10 Meter Assisted Walk. However, athlete walks the 50 meters using a walking aid.
 - d. Score: Same as the 10 Meter Assisted Walk.
14. **Ball Throw for Distance** (Tennis Ball) – This event provides meaningful competition to athletes with lower ability levels.
- a. Equipment:
 - 1) Tennis ball
 - 2) Chalk or tape
 - 3) Measuring tape
 - b. Set-Up:
 - 1) Same as Softball Throw.
 - c. Rules:
 - 1) Same as Softball Throw.
 - d. Score:
 - 1) Same as Softball Throw
15. **Ten Meter Wheelchair Event** – This event provides meaningful competition for athletes with lower ability levels.
- a. Equipment:
 - 1) Traffic cones
 - 2) Chalk





- 3) Stopwatch
- 4) Starter's Gun
- b. Set-Up:
 - 1) Mark the start and finish lines ten meters apart.
 - 2) Place cones on each line two meters apart, to create the start and finish gates.
 - 3) Create lanes by placing cones or chalk lines down the track between the start and finish gates.
- c. Rules:
 - 1) Athlete starts with all wheels of wheelchair behind the start line, in his/her wheelchair, facing the designated lane.
 - 2) Athlete begins racing at the sound of the starter's gun.
 - 3) Athlete must stay in his/her designated lane.
 - 4) The first two wheels must cross the plane of the finish line to receive an official time.
- d. Score:
 - 1) Athlete is timed from the smoke of the starter's gun to when the first two wheels of the wheelchair cross the plane of the finish line.

16. General Rules for Unified Sports Events

- a. Running or Walking
 - 1) Each Unified Sports Team shall consist of one Athlete and one Partner
 - 2) The final time for a Unified Sports Team shall be the sum of each competitor's finishing time.
 - 3) The first runner/walker from a Unified Sports Team to cross the finish line may not return to the course to pace/encourage their teammate.
- b. Field Events
 - 1) Each Unified Sports Team shall consist of one Athlete and one Partner
 - 2) The final score for a Unified Sports Team shall be the sum of each competitor's best attempt.
- c. Pentathlon
 - 1) Each Unified Sports Team shall consist of one Athlete and one Partner
 - 2) The final score for a Unified Sports Pentathlon Team shall be the sum of each competitor's total points.
- d. Relays
 - 1) Each Unified Sports Relay Team shall consist of two athletes and two Partners.
 - 2) Runners on a relay team may be assigned to run in any order.

Pentathlon First Event – 100 Meter Race (Score recorded in seconds.hundredths)

SCORE	POINTS	SCORE	POINTS	SCORE	POINTS	SCORE	POINTS
10.24	1200	10.69	1077	11.14	964	11.59	859
10.25	1197	10.70	1074	11.15	961	11.60	857
10.26	1194	10.71	1072	11.16	959	11.61	855
10.27	1191	10.72	1069	11.17	956	11.62	853
10.28	1188	10.73	1067	11.18	954	11.63	851
10.29	1186	10.74	1064	11.19	952	11.64	848
10.30	1183	10.75	1061	11.20	949	11.65	846
10.31	1180	10.76	1059	11.21	947	11.66	844
10.32	1177	10.77	1056	11.22	944	11.67	842
10.33	1174	10.78	1054	11.23	942	11.68	840
10.34	1172	10.79	1051	11.24	940	11.69	838
10.35	1169	10.80	1048	11.25	937	11.70	835
10.36	1166	10.81	1046	11.26	935	11.71	833
10.37	1163	10.82	1043	11.27	933	11.72	831
10.38	1160	10.83	1041	11.28	930	11.73	829
10.39	1158	10.84	1038	11.29	928	11.74	827
10.40	1155	10.85	1036	11.30	926	11.75	825
10.41	1152	10.86	1033	11.31	923	11.76	823
10.42	1149	10.87	1031	11.32	921	11.77	820
10.43	1147	10.88	1028	11.33	919	11.78	818
10.44	1144	10.89	1025	11.34	916	11.79	816
10.45	1141	10.90	1023	11.35	914	11.80	814
10.46	1138	10.91	1020	11.36	912	11.81	812
10.47	1136	10.92	1018	11.37	909	11.82	810
10.48	1133	10.93	1015	11.38	907	11.83	808
10.49	1130	10.94	1013	11.39	905	11.84	806
10.50	1128	10.95	1010	11.40	902	11.85	804
10.51	1125	10.96	1008	11.41	900	11.86	801
10.52	1122	10.97	1005	11.42	898	11.87	799
10.53	1120	10.98	1003	11.43	895	11.88	797
10.54	1117	10.99	1000	11.44	893	11.89	795
10.55	1114	11.00	998	11.45	891	11.90	793
10.56	1111	11.01	995	11.46	889	11.91	791
10.57	1109	11.02	993	11.47	886	11.92	789
10.58	1106	11.03	990	11.48	884	11.93	787
10.59	1103	11.04	988	11.49	882	11.94	785
10.60	1101	11.05	986	11.50	880	11.95	783
10.61	1098	11.06	983	11.51	877	11.96	781
10.62	1095	11.07	981	11.52	875	11.97	779
10.63	1093	11.08	978	11.53	873	11.98	777
10.64	1090	11.09	976	11.54	871	11.99	775
10.65	1087	11.10	973	11.55	868	12.00	773
10.66	1085	11.11	971	11.56	866	12.01	771
10.67	1082	11.12	968	11.57	864	12.02	769
10.68	1080	11.13	966	11.58	862	12.03	767



Pentathlon First Event – 100 Meter Race (Score recorded in seconds.hundredths)



SCORE	POINTS	SCORE	POINTS	SCORE	POINTS	SCORE	POINTS
12.04	765	12.49	679	12.94	603	13.39	536
12.05	763	12.50	677	12.95	601	13.40	534
12.06	761	12.51	675	12.96	600	13.41	533
12.07	759	12.52	674	12.97	598	13.42	532
12.08	757	12.53	672	12.98	596	13.43	530
12.09	755	12.54	670	12.99	595	13.44	529
12.10	753	12.55	668	13.00	593	13.45	527
12.11	751	12.56	667	13.01	592	13.46	526
12.12	749	12.57	665	13.02	590	13.47	525
12.13	747	12.58	663	13.03	589	13.48	523
12.14	745	12.59	661	13.04	587	13.49	522
12.15	743	12.60	660	13.05	585	13.50	521
12.16	741	12.61	658	13.06	584	13.51	519
12.17	739	12.62	656	13.07	582	13.52	518
12.18	737	12.63	654	13.08	581	13.53	517
12.19	735	12.64	653	13.09	579	13.54	515
12.20	733	12.65	651	13.10	578	13.55	514
12.21	731	12.66	649	13.11	576	13.56	513
12.22	729	12.67	647	13.12	575	13.57	511
12.23	727	12.68	646	13.13	573	13.58	510
12.24	725	12.69	644	13.14	572	13.59	509
12.25	724	12.70	642	13.15	570	13.60	508
12.26	722	12.71	641	13.16	569	13.61	506
12.27	720	12.72	639	13.17	567	13.62	505
12.28	718	12.73	637	13.18	566	13.63	504
12.29	716	12.74	635	13.19	564	13.64	502
12.30	714	12.75	634	13.20	563	13.65	501
12.31	712	12.76	632	13.21	561	13.66	500
12.32	710	12.77	630	13.22	560	13.67	499
12.33	708	12.78	629	13.23	558	13.68	497
12.34	707	12.79	627	13.24	557	13.69	496
12.35	705	12.80	625	13.25	556	13.70	495
12.36	703	12.81	624	13.26	554	13.71	494
12.37	701	12.82	622	13.27	553	13.72	492
12.38	699	12.83	621	13.28	551	13.73	491
12.39	697	12.84	619	13.29	550	13.74	490
12.40	695	12.85	617	13.30	548	13.75	489
12.41	694	12.86	616	13.31	547	13.76	487
12.42	692	12.87	614	13.32	545	13.77	486
12.43	690	12.88	612	13.33	544	13.78	485
12.44	688	12.89	611	13.34	543	13.79	484
12.45	686	12.90	609	13.35	541	13.80	483
12.46	684	12.91	608	13.36	540	13.81	481
12.47	683	12.92	606	13.37	538	13.82	480
12.48	681	12.93	604	13.38	537	13.83	479

Pentathlon First Event – 100 Meter Race (Score recorded in seconds.hundredths)

SCORE	POINTS	SCORE	POINTS	SCORE	POINTS	SCORE	POINTS
13.84	478	14.73	431	15.91	386	17.17	341
13.85	477	14.75	430	15.94	385	17.20	340
13.86	475	14.78	429	15.97	384	17.23	339
13.87	474	14.80	428	15.99	383	17.26	338
13.88	473	14.83	427	16.02	382	17.28	337
13.89	472	14.85	426	16.05	381	17.31	336
13.90	471	14.88	425	16.08	380	17.34	335
13.91	470	14.91	424	16.10	379	17.37	334
13.92	469	14.93	423	16.13	378	17.40	333
13.93	467	14.96	422	16.16	377	17.43	332
13.94	466	14.98	421	16.18	376	17.46	331
13.95	465	15.01	420	16.21	375	17.49	330
13.96	464	15.04	419	16.24	374	17.52	329
13.97	463	15.06	418	16.27	373	17.55	328
13.98	462	15.09	417	16.29	372	17.58	327
13.99	461	15.11	416	16.32	371	17.61	326
14.00	460	15.14	415	16.35	370	17.64	325
14.02	459	15.17	414	16.38	369	17.67	324
14.04	458	15.19	413	16.41	368	17.69	323
14.07	457	15.22	412	16.43	367	17.72	322
14.09	456	15.25	411	16.46	366	17.75	321
14.12	455	15.27	410	16.49	365	17.78	320
14.14	454	15.30	409	16.52	364	17.81	319
14.17	453	15.32	408	16.54	363	17.84	318
14.19	452	15.35	407	16.57	362	17.87	317
14.22	451	15.38	406	16.60	361	17.90	316
14.24	450	15.40	405	16.63	360	17.93	315
14.27	449	15.43	404	16.66	359	17.96	314
14.29	448	15.46	403	16.68	358	17.99	313
14.32	447	15.48	402	16.71	357	18.02	312
14.35	446	15.51	401	16.74	356	18.05	311
14.37	445	15.54	400	16.77	355	18.08	310
14.40	444	15.56	399	16.80	354	18.11	309
14.42	443	15.59	398	16.83	353	18.14	308
14.45	442	15.62	397	16.85	352	18.17	307
14.47	441	15.64	396	16.88	351	18.21	306
14.50	440	15.67	395	16.91	350	18.24	305
14.52	439	15.70	394	16.94	349	18.27	304
14.55	438	15.72	393	16.97	348	18.30	303
14.57	437	15.75	392	17.00	347	18.33	302
14.60	436	15.78	391	17.03	346	18.36	301
14.62	435	15.80	390	17.05	345	18.39	300
14.65	434	15.83	389	17.08	344	18.42	299
14.68	433	15.86	388	17.11	343	18.45	298
14.70	432	15.88	387	17.14	342	18.48	297



Pentathlon Second Event – Long Jump (Score recorded in meters/centimeters)



SCORE	POINTS	SCORE	POINTS	SCORE	POINTS	SCORE	POINTS
8.10	1200	7.63	1083	7.16	973	6.69	868
8.09	1197	7.62	1081	7.15	971	6.68	866
8.08	1194	7.61	1079	7.14	968	6.67	864
8.07	1192	7.60	1076	7.13	966	6.66	861
8.06	1189	7.59	1074	7.12	964	6.65	859
8.05	1187	7.58	1071	7.11	961	6.64	857
8.04	1184	7.57	1069	7.10	959	6.63	855
8.03	1182	7.56	1067	7.09	957	6.62	853
8.02	1179	7.55	1064	7.08	955	6.61	851
8.01	1177	7.54	1062	7.07	952	6.60	848
8.00	1174	7.53	1059	7.06	950	6.59	846
7.99	1172	7.52	1057	7.05	948	6.58	844
7.98	1169	7.51	1055	7.04	946	6.57	842
7.97	1167	7.50	1052	7.03	943	6.56	840
7.96	1164	7.49	1050	7.02	941	6.55	838
7.95	1162	7.48	1048	7.01	939	6.54	836
7.94	1159	7.47	1045	7.00	937	6.53	833
7.93	1157	7.46	1043	6.99	934	6.52	831
7.92	1154	7.45	1040	6.98	932	6.51	829
7.91	1152	7.44	1038	6.97	930	6.50	827
7.90	1149	7.43	1036	6.96	928	6.49	825
7.89	1147	7.42	1033	6.95	925	6.48	823
7.88	1145	7.41	1031	6.94	923	6.47	821
7.87	1142	7.40	1029	6.93	921	6.46	819
7.86	1140	7.39	1026	6.92	919	6.45	816
7.85	1137	7.38	1024	6.91	916	6.44	814
7.84	1135	7.37	1022	6.90	914	6.43	812
7.83	1132	7.36	1019	6.89	912	6.42	810
7.82	1130	7.35	1017	6.88	910	6.41	808
7.81	1127	7.34	1015	6.87	907	6.40	806
7.80	1125	7.33	1012	6.86	905	6.39	804
7.79	1122	7.32	1010	6.85	903	6.38	802
7.78	1120	7.31	1008	6.84	901	6.37	800
7.77	1117	7.30	1005	6.83	899	6.36	797
7.76	1115	7.29	1003	6.82	896	6.35	795
7.75	1113	7.28	1001	6.81	894	6.34	793
7.74	1110	7.27	998	6.80	892	6.33	791
7.73	1108	7.26	996	6.79	890	6.32	789
7.72	1105	7.25	994	6.78	888	6.31	787
7.71	1103	7.24	991	6.77	885	6.30	785
7.70	1100	7.23	989	6.76	883	6.29	783
7.69	1098	7.22	987	6.75	881	6.28	781
7.68	1096	7.21	984	6.74	879	6.27	779
7.67	1093	7.20	982	6.73	877	6.26	777
7.66	1091	7.19	980	6.72	874	6.25	775
7.65	1088	7.18	978	6.71	872	6.24	773
7.64	1086	7.17	975	6.70	870	6.23	770

Pentathlon Second Event – Long Jump (Score recorded in meters/centimeters)

SCORE	POINTS	SCORE	POINTS	SCORE	POINTS	SCORE	POINTS
6.22	768	5.75	674	5.28	586	4.81	503
6.21	766	5.74	673	5.27	584	4.80	501
6.20	764	5.73	671	5.26	582	4.79	500
6.19	762	5.72	669	5.25	581	4.78	498
6.18	760	5.71	667	5.24	579	4.77	496
6.17	758	5.70	665	5.23	577	4.76	495
6.16	756	5.69	663	5.22	575	4.75	493
6.15	754	5.68	661	5.21	573	4.74	491
6.14	752	5.67	659	5.20	572	4.73	490
6.13	750	5.66	657	5.19	570	4.72	488
6.12	748	5.65	655	5.18	568	4.71	486
6.11	746	5.64	653	5.17	566	4.70	484
6.10	744	5.63	651	5.16	564	4.69	483
6.09	742	5.62	649	5.15	563	4.68	481
6.08	740	5.61	648	5.14	561	4.67	479
6.07	738	5.60	646	5.13	559	4.66	478
6.06	736	5.59	644	5.12	557	4.65	476
6.05	734	5.58	642	5.11	555	4.64	474
6.04	732	5.57	640	5.10	554	4.63	473
6.03	730	5.56	638	5.09	552	4.62	471
6.02	728	5.55	636	5.08	550	4.61	469
6.01	726	5.54	634	5.07	548	4.60	468
6.00	724	5.53	632	5.06	547	4.59	466
5.99	722	5.52	630	5.05	545	4.58	465
5.98	720	5.51	629	5.04	543	4.57	463
5.97	718	5.50	627	5.03	541	4.56	461
5.96	716	5.49	625	5.02	539	4.55	460
5.95	714	5.48	623	5.01	538	4.54	458
5.94	712	5.47	621	5.00	536	4.53	456
5.93	710	5.46	619	4.99	534	4.52	455
5.92	708	5.45	617	4.98	532	4.51	453
5.91	706	5.44	615	4.97	531	4.50	451
5.90	704	5.43	614	4.96	529	4.49	450
5.89	702	5.42	612	4.95	527	4.48	448
5.88	700	5.41	610	4.94	525	4.47	447
5.87	698	5.40	608	4.93	524	4.46	445
5.86	696	5.39	606	4.92	522	4.45	443
5.85	694	5.38	604	4.91	520	4.44	442
5.84	692	5.37	603	4.90	519	4.43	440
5.83	690	5.36	601	4.89	517	4.42	438
5.82	688	5.35	599	4.88	515	4.41	437
5.81	686	5.34	597	4.87	513	4.40	435
5.80	684	5.33	595	4.86	512	4.39	434
5.79	682	5.32	593	4.85	510	4.38	432
5.78	680	5.31	591	4.84	508	4.37	430
5.77	678	5.30	590	4.83	507	4.36	429
5.76	676	5.29	588	4.82	505	4.35	427



Pentathlon Second Event – Long Jump (Score recorded in meters/centimeters)



SCORE	POINTS	SCORE	POINTS	SCORE	POINTS	SCORE	POINTS
4.34	426	3.87	354	3.40	288	2.93	227
4.33	424	3.86	352	3.39	286	2.92	225
4.32	423	3.85	351	3.38	285	2.91	224
4.31	421	3.84	349	3.37	283	2.90	223
4.30	419	3.83	348	3.36	282	2.89	222
4.29	418	3.82	347	3.35	281	2.88	221
4.28	416	3.81	345	3.34	279	2.87	219
4.27	415	3.80	344	3.33	278	2.86	218
4.26	413	3.79	342	3.32	277	2.85	217
4.25	412	3.78	341	3.31	275	2.84	216
4.24	410	3.77	339	3.30	274	2.83	215
4.23	408	3.76	338	3.29	273	2.82	213
4.22	407	3.75	336	3.28	271	2.81	212
4.21	405	3.74	335	3.27	270	2.80	211
4.20	404	3.73	334	3.26	269	2.79	210
4.19	402	3.72	332	3.25	268	2.78	208
4.18	401	3.71	331	3.24	266	2.77	207
4.17	399	3.70	329	3.23	265	2.76	206
4.16	398	3.69	328	3.22	264	2.75	205
4.15	396	3.68	326	3.21	262	2.74	204
4.14	394	3.67	325	3.20	261	2.73	203
4.13	393	3.66	324	3.19	260	2.72	201
4.12	391	3.65	322	3.18	258	2.71	200
4.11	390	3.64	321	3.17	257	2.70	199
4.10	388	3.63	319	3.16	256	2.69	198
4.09	387	3.62	318	3.15	254	2.68	197
4.08	385	3.61	316	3.14	253	2.67	195
4.07	384	3.60	315	3.13	252	2.66	194
4.06	382	3.59	314	3.12	251	2.65	193
4.05	381	3.58	312	3.11	249	2.64	192
4.04	379	3.57	311	3.10	248	2.63	191
4.03	378	3.56	309	3.09	247	2.62	190
4.02	376	3.55	308	3.08	246	2.61	188
4.01	375	3.54	307	3.07	244	2.60	187
4.00	373	3.53	305	3.06	243	2.59	186
3.99	372	3.52	304	3.05	242	2.58	185
3.98	370	3.51	303	3.04	240	2.57	184
3.97	369	3.50	301	3.03	239	2.56	183
3.96	367	3.49	300	3.02	238	2.55	182
3.95	366	3.48	298	3.01	237	2.54	180
3.94	364	3.47	297	3.00	235	2.53	179
3.93	363	3.46	296	2.99	234	2.52	178
3.92	361	3.45	294	2.98	233	2.51	177
3.91	360	3.44	293	2.97	232	2.50	176
3.90	358	3.43	292	2.96	230	2.49	175
3.89	357	3.42	290	2.95	229	2.48	174
3.88	355	3.41	289	2.94	228	2.47	173

Pentathlon Second Event – Long Jump (Score recorded in meters/centimeters)

SCORE	POINTS	SCORE	POINTS	SCORE	POINTS	SCORE	POINTS
2.46	171	1.99	122	1.49	75	0.90	28
2.45	170	1.98	121	1.48	74	0.89	27
2.44	169	1.97	120	1.47	73	0.88	26
2.43	168	1.96	119	1.46	72	0.86	25
2.42	167	1.95	118	1.45	71	0.85	24
2.41	166	1.94	117	1.43	70	0.83	23
2.40	165	1.93	116	1.42	69	0.82	22
2.39	164	1.92	115	1.41	68	0.81	21
2.38	163	1.91	114	1.40	67	0.79	20
2.37	161	1.90	113	1.39	66	0.78	19
2.36	160	1.89	112	1.37	65	0.76	18
2.35	159	1.88	111	1.36	64	0.75	17
2.34	158	1.87	110	1.35	63	0.73	16
2.33	157	1.86	109	1.34	62	0.72	15
2.32	156	1.85	108	1.33	61	0.70	14
2.31	155	1.84	107	1.31	60	0.69	13
2.30	154	1.83	106	1.30	59	0.67	12
2.29	153	1.82	105	1.29	58	0.66	11
2.28	152	1.81	104	1.28	57	0.64	10
2.27	151	1.80	103	1.27	56	0.63	9
2.26	150	1.79	102	1.25	55	0.61	8
2.25	149	1.78	101	1.24	54	0.60	7
2.24	147	1.77	100	1.23	53	0.58	6
2.23	146	1.76	99	1.22	52	0.57	5
2.22	145	1.75	98	1.20	51	0.55	4
2.21	144	1.73	97	1.19	50	0.54	3
2.20	143	1.72	96	1.18	49	0.52	2
2.19	142	1.71	95	1.17	48	0.50	1
2.18	141	1.70	94	1.15	47	0.49	0
2.17	140	1.69	93	1.14	46		
2.16	139	1.68	92	1.13	45		
2.15	138	1.67	91	1.12	44		
2.14	137	1.66	90	1.10	43		
2.13	136	1.65	89	1.09	42		
2.12	135	1.64	88	1.08	41		
2.11	134	1.63	87	1.06	40		
2.10	133	1.61	86	1.05	39		
2.09	132	1.60	85	1.04	38		
2.08	131	1.59	84	1.03	37		
2.07	130	1.58	83	1.01	36		
2.06	129	1.57	82	1.00	35		
2.05	128	1.56	81	0.99	34		
2.04	127	1.55	80	0.97	33		
2.03	126	1.54	79	0.96	32		
2.02	125	1.53	78	0.94	31		
2.01	124	1.51	77	0.93	30		
2.00	123	1.50	76	0.92	29		



Pentathlon Third Event – Shot Put (Score recorded in meters/centimeters)



SCORE	POINTS	SCORE	POINTS	SCORE	POINTS	SCORE	POINTS
14.78	824	14.05	777	13.31	730	12.57	683
14.77	823	14.04	776	13.30	729	12.55	682
14.75	822	14.02	775	13.28	728	12.54	681
14.74	821	14.01	774	13.27	727	12.52	680
14.72	820	13.99	773	13.25	726	12.50	679
14.71	819	13.97	772	13.23	725	12.49	678
14.69	818	13.96	771	13.22	724	12.47	677
14.68	817	13.94	770	13.20	723	12.46	676
14.66	816	13.93	769	13.19	722	12.44	675
14.64	815	13.91	768	13.17	721	12.42	674
14.63	814	13.90	767	13.16	720	12.41	673
14.61	813	13.88	766	13.14	719	12.39	672
14.60	812	13.86	765	13.12	718	12.38	671
14.58	811	13.85	764	13.11	717	12.36	670
14.57	810	13.83	763	13.09	716	12.34	669
14.55	809	13.82	762	13.08	715	12.33	668
14.54	808	13.80	761	13.06	714	12.31	667
14.52	807	13.79	760	13.04	713	12.30	666
14.50	806	13.77	759	13.03	712	12.28	665
14.49	805	13.75	758	13.01	711	12.26	664
14.47	804	13.74	757	13.00	710	12.25	663
14.46	803	13.72	756	12.98	709	12.23	662
14.44	802	13.71	755	12.97	708	12.22	661
14.43	801	13.69	754	12.95	707	12.20	660
14.41	800	13.68	753	12.93	706	12.18	659
14.40	799	13.66	752	12.92	705	12.17	658
14.38	798	13.64	751	12.90	704	12.15	657
14.36	797	13.63	750	12.89	703	12.14	656
14.35	796	13.61	749	12.87	702	12.12	655
14.33	795	13.60	748	12.85	701	12.10	654
14.32	794	13.58	747	12.84	700	12.09	653
14.30	793	13.57	746	12.82	699	12.07	652
14.29	792	13.55	745	12.81	698	12.06	651
14.27	791	13.53	744	12.79	697	12.04	650
14.26	790	13.52	743	12.77	696	12.02	649
14.24	789	13.50	742	12.76	695	12.01	648
14.22	788	13.49	741	12.74	694	11.99	647
14.21	787	13.47	740	12.73	693	11.97	646
14.19	786	13.46	739	12.71	692	11.96	645
14.18	785	13.44	738	12.69	691	11.94	644
14.16	784	13.42	737	12.68	690	11.93	643
14.15	783	13.41	736	12.66	689	11.91	642
14.13	782	13.39	735	12.65	688	11.89	641
14.11	781	13.38	734	12.63	687	11.88	640
14.10	780	13.36	733	12.62	686	11.86	639
14.08	779	13.34	732	12.60	685	11.85	638
14.07	778	13.33	731	12.58	684	11.83	637

Pentathlon Third Event – Shot Put (Score recorded in meters/centimeters)

SCORE	POINTS	SCORE	POINTS	SCORE	POINTS	SCORE	POINTS
11.81	636	11.05	589	10.28	542	9.51	495
11.80	635	11.04	588	10.27	541	9.49	494
11.78	634	11.02	587	10.25	540	9.47	493
11.77	633	11.00	586	10.23	539	9.46	492
11.75	632	10.99	585	10.22	538	9.44	491
11.73	631	10.97	584	10.20	537	9.42	490
11.72	630	10.95	583	10.18	536	9.41	489
11.70	629	10.94	582	10.17	535	9.39	488
11.68	628	10.92	581	10.15	534	9.37	487
11.67	627	10.91	580	10.14	533	9.36	486
11.65	626	10.89	579	10.12	532	9.34	485
11.64	625	10.87	578	10.10	531	9.32	484
11.62	624	10.86	577	10.09	530	9.31	483
11.60	623	10.84	576	10.07	529	9.29	482
11.59	622	10.82	575	10.05	528	9.27	481
11.57	621	10.81	574	10.04	527	9.26	480
11.56	620	10.79	573	10.02	526	9.24	479
11.54	619	10.78	572	10.00	525	9.22	478
11.52	618	10.76	571	9.99	524	9.21	477
11.51	617	10.74	570	9.97	523	9.19	476
11.49	616	10.73	569	9.95	522	9.17	475
11.47	615	10.71	568	9.94	521	9.16	474
11.46	614	10.69	567	9.92	520	9.14	473
11.44	613	10.68	566	9.90	519	9.12	472
11.43	612	10.66	565	9.89	518	9.11	471
11.41	611	10.64	564	9.87	517	9.09	470
11.39	610	10.63	563	9.85	516	9.07	469
11.38	609	10.61	562	9.84	515	9.06	468
11.36	608	10.60	561	9.82	514	9.04	467
11.35	607	10.58	560	9.80	513	9.02	466
11.33	606	10.56	559	9.79	512	9.01	465
11.31	605	10.55	558	9.77	511	8.99	464
11.30	604	10.53	557	9.76	510	8.97	463
11.28	603	10.51	556	9.74	509	8.96	462
11.26	602	10.50	555	9.72	508	8.94	461
11.25	601	10.48	554	9.71	507	8.92	460
11.23	600	10.46	553	9.69	506	8.91	459
11.22	599	10.45	552	9.67	505	8.89	458
11.20	598	10.43	551	9.66	504	8.87	457
11.18	597	10.42	550	9.64	503	8.85	456
11.17	596	10.40	549	9.62	502	8.84	455
11.15	595	10.38	548	9.61	501	8.82	454
11.13	594	10.37	547	9.59	500	8.80	453
11.12	593	10.35	546	9.57	499	8.79	452
11.10	592	10.33	545	9.56	498	8.77	451
11.09	591	10.32	544	9.54	497	8.75	450
11.07	590	10.30	543	9.52	496	8.74	449



Pentathlon Third Event – Shot Put (Score recorded in meters/centimeters)



SCORE	POINTS	SCORE	POINTS	SCORE	POINTS	SCORE	POINTS
8.72	448	7.93	401	7.12	354	6.31	307
8.70	447	7.91	400	7.10	353	6.29	306
8.69	446	7.89	399	7.09	352	6.27	305
8.67	445	7.87	398	7.07	351	6.26	304
8.65	444	7.86	397	7.05	350	6.24	303
8.64	443	7.84	396	7.04	349	6.22	302
8.62	442	7.82	395	7.02	348	6.20	301
8.60	441	7.81	394	7.00	347	6.19	300
8.59	440	7.79	393	6.98	346	6.17	299
8.57	439	7.77	392	6.97	345	6.15	298
8.55	438	7.76	391	6.95	344	6.13	297
8.54	437	7.74	390	6.93	343	6.12	296
8.52	436	7.72	389	6.92	342	6.10	295
8.50	435	7.70	388	6.90	341	6.08	294
8.48	434	7.69	387	6.88	340	6.06	293
8.47	433	7.67	386	6.86	339	6.05	292
8.45	432	7.65	385	6.85	338	6.03	291
8.43	431	7.64	384	6.83	337	6.01	290
8.42	430	7.62	383	6.81	336	5.99	289
8.40	429	7.60	382	6.79	335	5.98	288
8.38	428	7.58	381	6.78	334	5.96	287
8.37	427	7.57	380	6.76	333	5.94	286
8.35	426	7.55	379	6.74	332	5.93	285
8.33	425	7.53	378	6.73	331	5.91	284
8.32	424	7.52	377	6.71	330	5.89	283
8.30	423	7.50	376	6.69	329	5.87	282
8.28	422	7.48	375	6.67	328	5.85	281
8.26	421	7.47	374	6.66	327	5.84	280
8.25	420	7.45	373	6.64	326	5.82	279
8.23	419	7.43	372	6.62	325	5.80	278
8.21	418	7.41	371	6.60	324	5.78	277
8.20	417	7.40	370	6.59	323	5.77	276
8.18	416	7.38	369	6.57	322	5.75	275
8.16	415	7.36	368	6.55	321	5.73	274
8.15	414	7.35	367	6.53	320	5.71	273
8.13	413	7.33	366	6.52	319	5.70	272
8.11	412	7.31	365	6.50	318	5.68	271
8.10	411	7.29	364	6.48	317	5.66	270
8.08	410	7.28	363	6.47	316	5.64	269
8.06	409	7.26	362	6.45	315	5.63	268
8.04	408	7.24	361	6.43	314	5.61	267
8.03	407	7.23	360	6.41	313	5.59	266
8.01	406	7.21	359	6.40	312	5.57	265
7.99	405	7.19	358	6.38	311	5.56	264
7.98	404	7.17	357	6.36	310	5.54	263
7.96	403	7.16	356	6.34	309	5.52	262
7.94	402	7.14	355	6.33	308	5.50	261

Pentathlon Third Event – Shot Put (Score recorded in meters/centimeters)

SCORE	POINTS	SCORE	POINTS	SCORE	POINTS	SCORE	POINTS
5.49	260	4.65	213	3.81	166	2.96	119
5.47	259	4.64	212	3.79	165	2.94	118
5.45	258	4.62	211	3.77	164	2.92	117
5.43	257	4.60	210	3.76	163	2.90	116
5.42	256	4.58	209	3.74	162	2.88	115
5.40	255	4.56	208	3.72	161	2.86	114
5.38	254	4.55	207	3.70	160	2.85	113
5.36	253	4.53	206	3.68	159	2.83	112
5.35	252	4.51	205	3.67	158	2.81	111
5.33	251	4.49	204	3.65	157	2.79	110
5.31	250	4.47	203	3.63	156	2.77	109
5.29	249	4.46	202	3.61	155	2.75	108
5.27	248	4.44	201	3.59	154	2.74	107
5.26	247	4.42	200	3.57	153	2.72	106
5.24	246	4.40	199	3.56	152	2.70	105
5.22	245	4.39	198	3.54	151	2.68	104
5.20	244	4.37	197	3.52	150	2.66	103
5.19	243	4.35	196	3.50	149	2.64	102
5.17	242	4.33	195	3.48	148	2.63	101
5.15	241	4.31	194	3.47	147	2.61	100
5.13	240	4.30	193	3.45	146	2.59	99
5.12	239	4.28	192	3.43	145	2.57	98
5.10	238	4.26	191	3.41	144	2.55	97
5.08	237	4.24	190	3.39	143	2.53	96
5.06	236	4.22	189	3.38	142	2.52	95
5.04	235	4.21	188	3.36	141	2.50	94
5.03	234	4.19	187	3.34	140	2.48	93
5.01	233	4.17	186	3.32	139	2.46	92
4.99	232	4.15	185	3.30	138	2.44	91
4.97	231	4.13	184	3.28	137	2.42	90
4.96	230	4.12	183	3.27	136	2.40	89
4.94	229	4.10	182	3.25	135	2.39	88
4.92	228	4.08	181	3.23	134	2.37	87
4.90	227	4.06	180	3.21	133	2.35	86
4.88	226	4.04	179	3.19	132	2.33	85
4.87	225	4.03	178	3.17	131	2.31	84
4.85	224	4.01	177	3.16	130	2.29	83
4.83	223	3.99	176	3.14	129	2.28	82
4.81	222	3.97	175	3.12	128	2.26	81
4.80	221	3.95	174	3.10	127	2.24	80
4.78	220	3.94	173	3.08	126	2.22	79
4.76	219	3.92	172	3.07	125	2.20	78
4.74	218	3.90	171	3.05	124	2.18	77
4.72	217	3.88	170	3.03	123	2.16	76
4.71	216	3.86	169	3.01	122	2.15	75
4.69	215	3.85	168	2.99	121	2.13	74
4.67	214	3.83	167	2.97	120	2.11	73



Pentathlon Fourth Event – High Jump (Score recorded in meters/centimeters)



SCORE	POINTS	SCORE	POINTS	SCORE	POINTS
2.29	1200	1.82	799	1.35	438
2.28	1191	1.81	791	1.34	430
2.27	1182	1.80	783	1.33	423
2.26	1173	1.79	775	1.32	416
2.25	1164	1.78	767	1.31	409
2.24	1155	1.77	759	1.30	401
2.23	1146	1.76	751	1.29	394
2.22	1138	1.75	743	1.28	387
2.21	1129	1.74	735	1.27	380
2.20	1120	1.73	727	1.26	373
2.19	1111	1.72	719	1.25	366
2.18	1102	1.71	711	1.24	359
2.17	1094	1.70	703	1.23	351
2.16	1085	1.69	695	1.22	344
2.15	1076	1.68	688	1.21	337
2.14	1068	1.67	680	1.20	330
2.13	1059	1.66	672	1.19	323
2.12	1050	1.65	664	1.18	316
2.11	1042	1.64	656	1.17	309
2.10	1033	1.63	649	1.16	302
2.09	1025	1.62	641	1.15	295
2.08	1016	1.61	633	1.14	288
2.07	1007	1.60	625	1.13	282
2.06	999	1.59	618	1.12	275
2.05	990	1.58	610	1.11	268
2.04	982	1.57	602	1.10	261
2.03	973	1.56	595	1.09	254
2.02	965	1.55	587	1.08	247
2.01	957	1.54	579	1.07	240
2.00	948	1.53	572	1.06	234
1.99	940	1.52	564	1.05	227
1.98	931	1.51	556	1.04	220
1.97	923	1.50	549	1.03	213
1.96	915	1.49	541	1.02	207
1.95	906	1.48	534	1.01	200
1.94	898	1.47	526	1.00	193
1.93	890	1.46	519	0.99	187
1.92	881	1.45	511	0.98	180
1.91	873	1.44	504	0.97	173
1.90	865	1.43	497	0.96	167
1.89	857	1.42	489	0.95	160
1.88	848	1.41	482	0.94	153
1.87	840	1.40	474	0.93	147
1.86	832	1.39	467	0.92	140
1.85	824	1.38	460	0.91	134
1.84	816	1.37	452	0.90	127
1.83	808	1.36	445		

Pentathlon Fifth Event – 400 Meter Race (Score recorded in seconds.hundredths)

SCORE	POINTS	SCORE	POINTS	SCORE	POINTS	SCORE	POINTS
45.40	1200	46.29	1153	47.22	1106	48.16	1059
45.41	1199	46.31	1152	47.23	1105	48.18	1058
45.43	1198	46.33	1151	47.25	1104	48.20	1057
45.45	1197	46.35	1150	47.27	1103	48.22	1056
45.47	1196	46.37	1149	47.29	1102	48.24	1055
45.49	1195	46.39	1148	47.31	1101	48.26	1054
45.51	1194	46.41	1147	47.33	1100	48.28	1053
45.53	1193	46.43	1146	47.35	1099	48.30	1052
45.55	1192	46.45	1145	47.37	1098	48.32	1051
45.57	1191	46.47	1144	47.39	1097	48.34	1050
45.58	1190	46.49	1143	47.41	1096	48.36	1049
45.60	1189	46.51	1142	47.43	1095	48.38	1048
45.62	1188	46.53	1141	47.45	1094	48.40	1047
45.64	1187	46.55	1140	47.47	1093	48.42	1046
45.66	1186	46.57	1139	47.49	1092	48.44	1045
45.68	1185	46.59	1138	47.51	1091	48.46	1044
45.70	1184	46.61	1137	47.53	1090	48.49	1043
45.72	1183	46.62	1136	47.55	1089	48.51	1042
45.74	1182	46.64	1135	47.57	1088	48.53	1041
45.76	1181	46.66	1134	47.59	1087	48.55	1040
45.78	1180	46.68	1133	47.61	1086	48.57	1039
45.79	1179	46.70	1132	47.63	1085	48.59	1038
45.81	1178	46.72	1131	47.65	1084	48.61	1037
45.83	1177	46.74	1130	47.67	1083	48.63	1036
45.85	1176	46.76	1129	47.69	1082	48.65	1035
45.87	1175	46.78	1128	47.71	1081	48.67	1034
45.89	1174	46.80	1127	47.73	1080	48.69	1033
45.91	1173	46.82	1126	47.75	1079	48.71	1032
45.93	1172	46.84	1125	47.77	1078	48.73	1031
45.95	1171	46.86	1124	47.79	1077	48.75	1030
45.97	1170	46.88	1123	47.81	1076	48.77	1029
45.99	1169	46.90	1122	47.83	1075	48.79	1028
46.01	1168	46.92	1121	47.85	1074	48.81	1027
46.02	1167	46.94	1120	47.87	1073	48.84	1026
46.04	1166	46.96	1119	47.90	1072	48.86	1025
46.06	1165	46.98	1118	47.92	1071	48.88	1024
46.08	1164	47.00	1117	47.94	1070	48.90	1023
46.10	1163	47.02	1116	47.96	1069	48.92	1022
46.12	1162	47.04	1115	47.98	1068	48.94	1021
46.14	1161	47.06	1114	48.00	1067	48.96	1020
46.16	1160	47.08	1113	48.02	1066	48.98	1019
46.18	1159	47.10	1112	48.04	1065	49.00	1018
46.20	1158	47.12	1111	48.06	1064	49.02	1017
46.22	1157	47.14	1110	48.08	1063	49.04	1016
46.24	1156	47.16	1109	48.10	1062	49.06	1015
46.26	1155	47.18	1108	48.12	1061	49.08	1014
46.28	1154	47.20	1107	48.14	1060	49.11	1013



Pentathlon Fifth Event – 400 Meter Race (Score recorded in seconds.hundredths)



SCORE	POINTS	SCORE	POINTS	SCORE	POINTS	SCORE	POINTS
49.13	1012	50.12	965	51.14	918	52.20	871
49.15	1011	50.14	964	51.17	917	52.22	870
49.17	1010	50.16	963	51.19	916	52.24	869
49.19	1009	50.19	962	51.21	915	52.27	868
49.21	1008	50.21	961	51.23	914	52.29	867
49.23	1007	50.23	960	51.25	913	52.31	866
49.25	1006	50.25	959	51.28	912	52.34	865
49.27	1005	50.27	958	51.30	911	52.36	864
49.29	1004	50.29	957	51.32	910	52.38	863
49.31	1003	50.31	956	51.34	909	52.40	862
49.34	1002	50.34	955	51.37	908	52.43	861
49.36	1001	50.36	954	51.39	907	52.45	860
49.38	1000	50.38	953	51.41	906	52.47	859
49.40	999	50.40	952	51.43	905	52.50	858
49.42	998	50.42	951	51.45	904	52.52	857
49.44	997	50.44	950	51.48	903	52.54	856
49.46	996	50.47	949	51.50	902	52.57	855
49.48	995	50.49	948	51.52	901	52.59	854
49.50	994	50.51	947	51.54	900	52.61	853
49.52	993	50.53	946	51.57	899	52.64	852
49.55	992	50.55	945	51.59	898	52.66	851
49.57	991	50.57	944	51.61	897	52.68	850
49.59	990	50.60	943	51.63	896	52.70	849
49.61	989	50.62	942	51.66	895	52.73	848
49.63	988	50.64	941	51.68	894	52.75	847
49.65	987	50.66	940	51.70	893	52.77	846
49.67	986	50.68	939	51.72	892	52.80	845
49.69	985	50.70	938	51.75	891	52.82	844
49.72	984	50.73	937	51.77	890	52.84	843
49.74	983	50.75	936	51.79	889	52.87	842
49.76	982	50.77	935	51.81	888	52.89	841
49.78	981	50.79	934	51.84	887	52.91	840
49.80	980	50.81	933	51.86	886	52.94	839
49.82	979	50.84	932	51.88	885	52.96	838
49.84	978	50.86	931	51.90	884	52.98	837
49.86	977	50.88	930	51.93	883	53.01	836
49.89	976	50.90	929	51.95	882	53.03	835
49.91	975	50.92	928	51.97	881	53.05	834
49.93	974	50.95	927	51.99	880	53.08	833
49.95	973	50.97	926	52.02	879	53.10	832
49.97	972	50.99	925	52.04	878	53.12	831
49.99	971	51.01	924	52.06	877	53.15	830
50.01	970	51.03	923	52.09	876	53.17	829
50.04	969	51.06	922	52.11	875	53.19	828
50.06	968	51.08	921	52.13	874	53.22	827
50.08	967	51.10	920	52.15	873	53.24	826
50.10	966	51.12	919	52.18	872	53.27	825

Pentathlon Fifth Event – 400 Meter Race (Score recorded in seconds.hundredths)

SCORE	POINTS	SCORE	POINTS	SCORE	POINTS	SCORE	POINTS
53.29	824	54.42	777	55.59	730	56.81	683
53.31	823	54.44	776	55.61	729	56.83	682
53.34	822	54.47	775	55.64	728	56.86	681
53.36	821	54.49	774	55.66	727	56.89	680
53.38	820	54.51	773	55.69	726	56.91	679
53.41	819	54.54	772	55.71	725	56.94	678
53.43	818	54.56	771	55.74	724	56.97	677
53.45	817	54.59	770	55.77	723	56.99	676
53.48	816	54.61	769	55.79	722	57.02	675
53.50	815	54.64	768	55.82	721	57.05	674
53.53	814	54.66	767	55.84	720	57.07	673
53.55	813	54.69	766	55.87	719	57.10	672
53.57	812	54.71	765	55.89	718	57.13	671
53.60	811	54.74	764	55.92	717	57.15	670
53.62	810	54.76	763	55.95	716	57.18	669
53.64	809	54.79	762	55.97	715	57.21	668
53.67	808	54.81	761	56.00	714	57.23	667
53.69	807	54.84	760	56.02	713	57.26	666
53.72	806	54.86	759	56.05	712	57.29	665
53.74	805	54.88	758	56.07	711	57.31	664
53.76	804	54.91	757	56.10	710	57.34	663
53.79	803	54.93	756	56.13	709	57.37	662
53.81	802	54.96	755	56.15	708	57.39	661
53.84	801	54.98	754	56.18	707	57.42	660
53.86	800	55.01	753	56.20	706	57.45	659
53.88	799	55.03	752	56.23	705	57.48	658
53.91	798	55.06	751	56.26	704	57.50	657
53.93	797	55.08	750	56.28	703	57.53	656
53.96	796	55.11	749	56.31	702	57.56	655
53.98	795	55.13	748	56.33	701	57.58	654
54.00	794	55.16	747	56.36	700	57.61	653
54.03	793	55.18	746	56.39	699	57.64	652
54.05	792	55.21	745	56.41	698	57.67	651
54.08	791	55.23	744	56.44	697	57.69	650
54.10	790	55.26	743	56.46	696	57.72	649
54.12	789	55.28	742	56.49	695	57.75	648
54.15	788	55.31	741	56.52	694	57.78	647
54.17	787	55.33	740	56.54	693	57.80	646
54.20	786	55.36	739	56.57	692	57.83	645
54.22	785	55.38	738	56.60	691	57.86	644
54.25	784	55.41	737	56.62	690	57.89	643
54.27	783	55.44	736	56.65	689	57.91	642
54.29	782	55.46	735	56.67	688	57.94	641
54.32	781	55.49	734	56.70	687	57.97	640
54.34	780	55.51	733	56.73	686	58.00	639
54.37	779	55.54	732	56.75	685	58.02	638
54.39	778	55.56	731	56.78	684	58.05	637



Pentathlon Fifth Event – 400 Meter Race (Score recorded in seconds.hundredths)



SCORE	POINTS	SCORE	POINTS	SCORE	POINTS	SCORE	POINTS
58.08	636	59.41	589	60.82	542	62.32	495
58.11	635	59.44	588	60.85	541	62.35	494
58.13	634	59.47	587	60.88	540	62.38	493
58.16	633	59.50	586	60.92	539	62.42	492
58.19	632	59.53	585	60.95	538	62.45	491
58.22	631	59.56	584	60.98	537	62.48	490
58.25	630	59.59	583	61.01	536	62.52	489
58.27	629	59.62	582	61.04	535	62.55	488
58.30	628	59.65	581	61.07	534	62.58	487
58.33	627	59.68	580	61.10	533	62.61	486
58.36	626	59.71	579	61.13	532	62.65	485
58.39	625	59.74	578	61.16	531	62.68	484
58.41	624	59.77	577	61.20	530	62.71	483
58.44	623	59.80	576	61.23	529	62.75	482
58.47	622	59.83	575	61.26	528	62.78	481
58.50	621	59.86	574	61.29	527	62.81	480
58.53	620	59.89	573	61.32	526	62.85	479
58.55	619	59.92	572	61.35	525	62.88	478
58.58	618	59.94	571	61.38	524	62.92	477
58.61	617	59.97	570	61.42	523	62.95	476
58.64	616	60.00	569	61.45	522	62.98	475
58.67	615	60.03	568	61.48	521	63.02	474
58.70	614	60.06	567	61.51	520	63.05	473
58.72	613	60.09	566	61.54	519	63.08	472
58.75	612	60.12	565	61.57	518	63.12	471
58.78	611	60.15	564	61.61	517	63.15	470
58.81	610	60.18	563	61.64	516	63.19	469
58.84	609	60.21	562	61.67	515	63.22	468
58.87	608	60.24	561	61.70	514	63.26	467
58.90	607	60.27	560	61.73	513	63.29	466
58.92	606	60.30	559	61.77	512	63.32	465
58.95	605	60.33	558	61.80	511	63.36	464
58.98	604	60.37	557	61.83	510	63.39	463
59.01	603	60.40	556	61.86	509	63.43	462
59.04	602	60.43	555	61.89	508	63.46	461
59.07	601	60.46	554	61.93	507	63.50	460
59.10	600	60.49	553	61.96	506	63.53	459
59.13	599	60.52	552	61.99	505	63.57	458
59.15	598	60.55	551	62.02	504	63.60	457
59.18	597	60.58	550	62.06	503	63.64	456
59.21	596	60.61	549	62.09	502	63.67	455
59.24	595	60.64	548	62.12	501	63.70	454
59.27	594	60.67	547	62.15	500	63.74	453
59.30	593	60.70	546	62.19	499	63.77	452
59.33	592	60.73	545	62.22	498	63.81	451
59.36	591	60.76	544	62.25	497	63.84	450
59.39	590	60.79	543	62.28	496	63.88	449

Pentathlon Fifth Event – 400 Meter Race (Score recorded in seconds.hundredths)

SCORE	POINTS	SCORE	POINTS	SCORE	POINTS	SCORE	POINTS
63.92	448	65.64	401	67.54	354	69.66	307
63.95	447	65.68	400	67.58	353	69.71	306
63.99	446	65.72	399	67.62	352	69.75	305
64.02	445	65.76	398	67.66	351	69.80	304
64.06	444	65.80	397	67.71	350	69.85	303
64.09	443	65.84	396	67.75	349	69.90	302
64.13	442	65.87	395	67.79	348	69.95	301
64.16	441	65.91	394	67.84	347	70.00	300
64.20	440	65.95	393	67.88	346	70.20	299
64.24	439	65.99	392	67.92	345	70.40	298
64.27	438	66.03	391	67.97	344	70.60	297
64.31	437	66.07	390	68.01	343	70.80	296
64.34	436	66.11	389	68.05	342	71.00	295
64.38	435	66.15	388	68.10	341	71.20	294
64.41	434	66.19	387	68.14	340	71.40	293
64.45	433	66.23	386	68.18	339	71.61	292
64.49	432	66.27	385	68.23	338	71.81	291
64.52	431	66.31	384	68.27	337	72.01	290
64.56	430	66.35	383	68.32	336	72.21	289
64.60	429	66.39	382	68.36	335	72.42	288
64.63	428	66.43	381	68.41	334	72.62	287
64.67	427	66.47	380	68.45	333	72.83	286
64.71	426	66.51	379	68.50	332	73.03	285
64.74	425	66.55	378	68.54	331	73.23	284
64.78	424	66.59	377	68.59	330	73.44	283
64.82	423	66.63	376	68.63	329	73.64	282
64.85	422	66.67	375	68.68	328	73.85	281
64.89	421	66.71	374	68.72	327	74.06	280
64.93	420	66.75	373	68.77	326	74.26	279
64.96	419	66.79	372	68.81	325	74.47	278
65.00	418	66.83	371	68.86	324	74.68	277
65.04	417	66.87	370	68.90	323	74.89	276
65.08	416	66.91	369	68.95	322	75.09	275
65.11	415	66.95	368	69.00	321	75.30	274
65.15	414	66.99	367	69.04	320	75.51	273
65.19	413	67.03	366	69.09	319	75.72	272
65.23	412	67.08	365	69.14	318	75.93	271
65.26	411	67.12	364	69.18	317	76.14	270
65.30	410	67.16	363	69.23	316	76.35	269
65.34	409	67.20	362	69.28	315	76.56	268
65.38	408	67.24	361	69.32	314	76.77	267
65.41	407	67.28	360	69.37	313	76.98	266
65.45	406	67.33	359	69.42	312	77.19	265
65.49	405	67.37	358	69.47	311	77.41	264
65.53	404	67.41	357	69.51	310	77.62	263
65.57	403	67.45	356	69.56	309	77.83	262
65.60	402	67.49	355	69.61	308	78.05	261



Pentathlon Fifth Event – 400 Meter Race (Score recorded in seconds.hundredths)



SCORE	POINTS	SCORE	POINTS	SCORE	POINTS	SCORE	POINTS
78.26	260	88.82	213	100.62	166	114.24	119
78.47	259	89.06	212	100.89	165	114.56	118
78.69	258	89.30	211	101.16	164	114.88	117
78.90	257	89.54	210	101.43	163	115.19	116
79.12	256	89.77	209	101.70	162	115.51	115
79.34	255	90.01	208	101.97	161	115.84	114
79.55	254	90.25	207	102.25	160	116.16	113
79.77	253	90.49	206	102.52	159	116.48	112
79.99	252	90.73	205	102.79	158	116.81	111
80.20	251	90.97	204	103.07	157	117.14	110
80.42	250	91.22	203	103.34	156	117.47	109
80.64	249	91.46	202	103.62	155	117.80	108
80.86	248	91.70	201	103.90	154	118.13	107
81.08	247	91.95	200	104.17	153	118.46	106
81.30	246	92.19	199	104.45	152	118.80	105
81.52	245	92.43	198	104.73	151	119.13	104
81.74	244	92.68	197	105.02	150	119.47	103
81.96	243	92.93	196	105.30	149	119.81	102
82.18	242	93.17	195	105.58	148	120.15	101
82.41	241	93.42	194	105.86	147	120.50	100
82.63	240	93.67	193	106.15	146	120.84	99
82.85	239	93.92	192	106.43	145	121.19	98
83.07	238	94.17	191	106.72	144	121.54	97
83.30	237	94.42	190	107.01	143	121.89	96
83.52	236	94.67	189	107.30	142	122.24	95
83.75	235	94.92	188	107.59	141	122.59	94
83.97	234	95.17	187	107.88	140	122.95	93
84.20	233	95.42	186	108.17	139	123.31	92
84.43	232	95.68	185	108.46	138	123.67	91
84.65	231	95.93	184	108.76	137	124.03	90
84.88	230	96.18	183	109.05	136	124.39	89
85.11	229	96.44	182	109.35	135	124.76	88
85.34	228	96.70	181	109.64	134	125.12	87
85.57	227	96.95	180	109.94	133	125.49	86
85.79	226	97.21	179	110.24	132	125.87	85
86.02	225	97.47	178	110.54	131	126.24	84
86.25	224	97.73	177	110.84	130	126.62	83
86.49	223	97.99	176	111.15	129	126.99	82
86.72	222	98.25	175	111.45	128	127.38	81
86.95	221	98.51	174	111.76	127	127.76	80
87.18	220	98.77	173	112.06	126	128.14	79
87.41	219	99.03	172	112.37	125	128.53	78
87.65	218	99.30	171	112.68	124	128.92	77
87.88	217	99.56	170	112.99	123	129.31	76
88.12	216	99.83	169	113.30	122	129.71	75
88.35	215	100.09	168	113.61	121	130.11	74
88.59	214	100.36	167	113.93	120	130.51	73